

X-RAIL



About Rollon



Development of global business

- 1975** Parent company, Rollon S.r.l., founded in Italy
- 1991** Founding of Rollon GmbH in Germany
- 1995** Expansion of headquarters to new 4,000 m² factory
Assembly starts in Germany
Quality management certified to ISO 9001
- 1998** Rollon B.V. in the Netherlands and Rollon Corporation in the USA are founded
Expansion of German branch to new 1,000 m² plant
- 1999** Founding of Rollon S.A.R.L. in France
Environmental management certified to ISO 14001
- 2000** Rollon s.r.o. founded in Czech Republic
- 2001** Expansion of headquarters to new 12,000 m² manufacturing plant
- 2007** Restructuring of the GmbH and alignment of production in Germany to customer-specific adaptations
Takeover of the assets of a manufacturer of linear rail systems
- 2008** Expansion of sales network in Eastern Europe and Asia

Continual expansion and optimization of the portfolio

Founded in 1975, Rollon manufactured high-precision linear roller bearings for the machine tool industry. Early on, Rollon started manufacturing linear bearings based on the bearing-cage design. In 1979, the Compact Rail self-aligning linear bearings joined the Telescopic Rail industrial drawer slides and Easy Rail linear bearings and became the basis of the strong foundation on which the company is building upon today. Continuing optimization of these core products still remains one of the most important goals at Rollon. The development of the patented Compact Rail linear bearing, which uses different proprietary rail profiles and high-precision radial ball bearing sliders, enables the compensation of height and angle mounting defects in applications, and is only one example of the continuing efforts to innovative the development of our existing product families. In the same manner, we continually introduce innovative new product families displaying our continuing product development and optimization in the industry. These include:

- 1994 Light Rail - full and partial extension telescopic in lightweight design
- 1996 Uniline - belt driven linear actuators
- 2001 Ecoline - economical aluminum linear actuators
- 2002 X-Rail - inexpensive formed steel linear guides
- 2004 Curviline - curved monorail profile rail guide with roller carriages
- 2007 Monorail - miniature sizes and full sized

Each further innovation of our linear bearings is built upon the our extensive knowledge of the nine product families in production today as well as on the current market demands. Rollon is the ultimate linear technology for any application needs.

Content

1 Product explanation

Linear bearings either in corrosion resistant or
zinc-plated steel 4

2 Technical data

Performance characteristics and notes 6
Load capacities 7

3 Product dimensions

Fixed bearings 8
Compensating bearings 10
Mounted sliders and rails 12
Telescopic drawer slide 13

4 Accessories

Rollers 14
Screws 15

5 Technical instructions

Lubrication, T+U-System 16
Setting preload, Telescopic drawer slide mounting 18

Ordering key

Ordering key with explanations

Portfolio

Product explanation

X-Rail: Corrosion resistant or zinc-plated steel linear bearings



Fig. 1

X-Rail is the product family of roller embossed guide rails for applications in which an especially economical price/performance ratio and high corrosion resistance are required.

X-Rail consists of three product series: fixed bearing rails, compensating bearing rails and telescopic extension on roller base.

All products are available in stainless steel or zinc-plated steel. There are three different sizes of guide rails. The sliders for the guide rails are available in different versions.

The most important characteristics:

- Corrosion resistant, FDA/USDA compliant materials
- Compensates for deviations in mounting structure parallelism
- Not sensitive to dirt due to internal tracks
- Wide temperature range of application
- Easy adjustment of sliders on the guide rails

Preferred areas of application of the X-Rail product family:

- Construction and machine technology (e.g., safety doors, washing bay accessories)
- Medical technology (e.g., hospital accessories, medical equipment)
- Transport (e.g., rail transport, naval, automotive industry)
- Food and beverage industry (e.g., packaging, food processing)
- Building technology (e.g., blinds)
- Energy technology (e.g., industrial furnaces, boilers)

Fixed bearings (T-rails)

Fixed bearing rails are used for the main load bearing in radial and axial forces.



Fig. 2

Compensating bearings (U-rails)

Compensating bearing rails are used for load bearing of radial forces and, in combination with fixed bearing rails as support bearings for occurring torques.



Fig. 3

System (T+U-System)

A T and U used together offers compensation for deviations in parallelism and tolerances in the mounting structure.



Fig. 4

Telescopic drawer slide

Telescopic rails with full extension bridge the gap between cheap drawer slides and heavy-load telescopic rails.



Fig. 5

Rollers

Concentric and eccentric radial ball bearings made of stainless steel or roller bearing steel are available for each slider. Roller sealing is dependent on the material: 2RS rubber seals or 2Z steel shields. All rollers are lubricated for life.



Fig. 6

Technical data

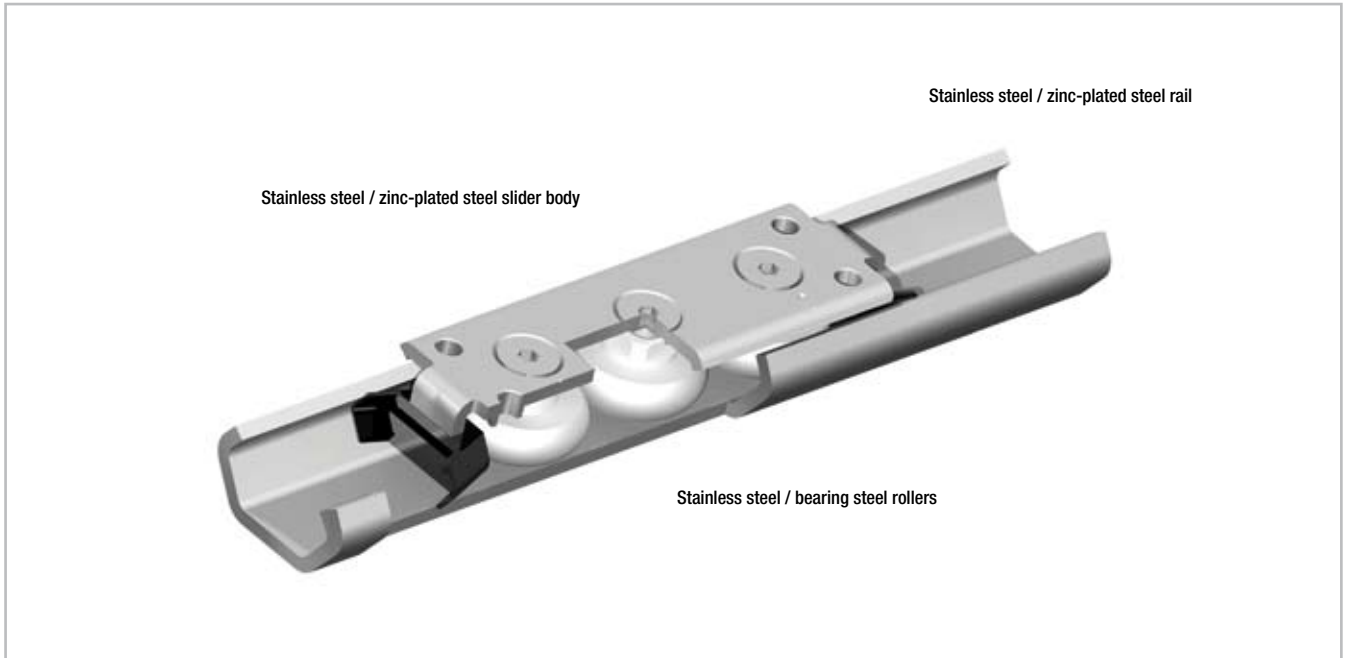

Fig. 7

Performance characteristics:

- Available sizes: 20, 30, 45
- Max. slider operating speeds in the linear bearing rails: 1.5 m/s (59 in/s) (depending on application)
- Max. telescoping speed: 0.8 m/s (31.5 in/s) (depending on application)
- Max. acceleration: 2 m/s² (78 in/s²) (depending on application)
- Max. traverse: 3,060 mm (120 in) (depending on size)
- Max. radial load capacity: 1,740 N (per slider)
- Temperature range for stainless steel rails: -30 °C to +100 °C (-22 °F to +212 °F), or steel rails: -30 °C to +120 °C (-22 °F to +248 °F)
- Available rail lengths from 160 mm to 3,120 mm (6.3 in to 122 in) in 80-mm increments (3.15 in)
- Rollers lubricated for life
- Roller seal/shield: CEX... Sliders => 2RS (splashproof seal), CES... Sliders => 2Z (dust cover seal)
- Material: Stainless steel rails TEX... / UEX... 1.4404 (AISI 316L), Steel rails TES... / UES... zinc-plated ISO 2081
- Material rollers: Stainless steel 1.4110 (AISI 440)

Remarks:

- The sliders are equipped with rollers that are in alternating contact with both sides of the raceway. Markings on the body around the outer roller pins indicate the correct arrangement of the rollers to the external load.
Important: Both outside rollers carry the radial load.
- By a simple adjustment of the eccentric roller, the slider has clearance or is set with the desired pre-stress on the rails.
- Sliders of Version 1 (with compact body) come standard with plastic wipers for cleaning the raceways.
- Wipers for sliders of Versions 2 and 3 on request.
- We do not recommend combining (stringing together) the rails.
- Recommended fixing screws according to ISO 7380 with low head height or TORX® screws on request.

Load capacities

Fixed bearings

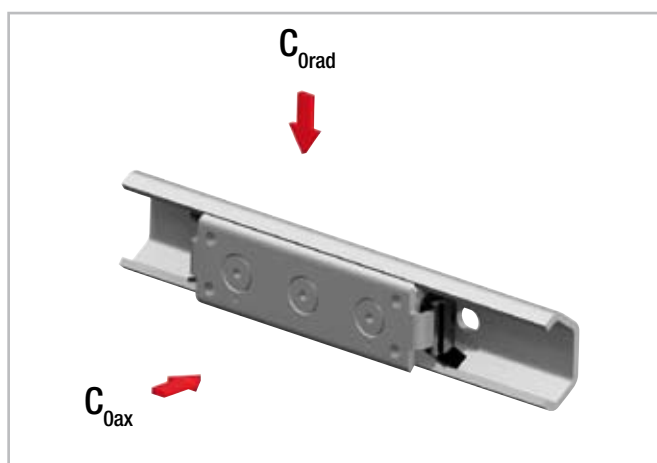

Fig. 8

Configuration	C_{Orad} [N]	C_{Oax} [N]
TEX-20 – CEX20	300	170
TEX-30 – CEX30	800	400
TEX-45 – CEX45	1600	860
TES-20 – CES20	326	185
TES-30 – CES30	870	435
TES-45 – CES45	1740	935

Tab. 1

Resulting moment loads must be absorbed through the use of two sliders

Compensating bearings

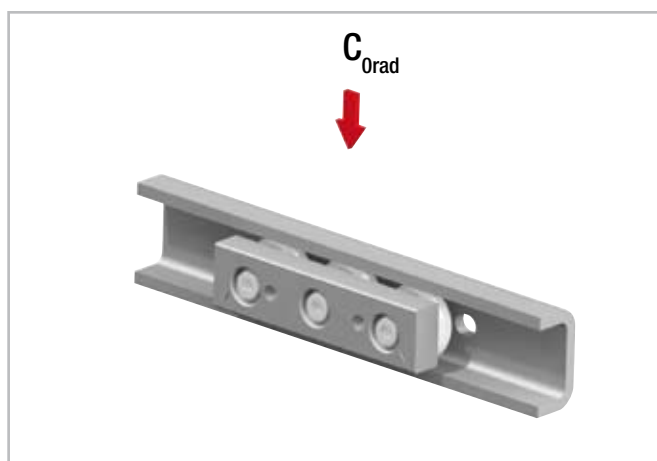

Fig. 9

Configuration	C_{Orad} [N]
UEX-20 – CEXU20	300
UEX-30 – CEXU30	800
UEX-45 – CEXU45	1600
UES-20 – CESU20	326
UES-30 – CESU30	870
UES-45 – CESU45	1740

Tab. 2

Telescopic drawer slide

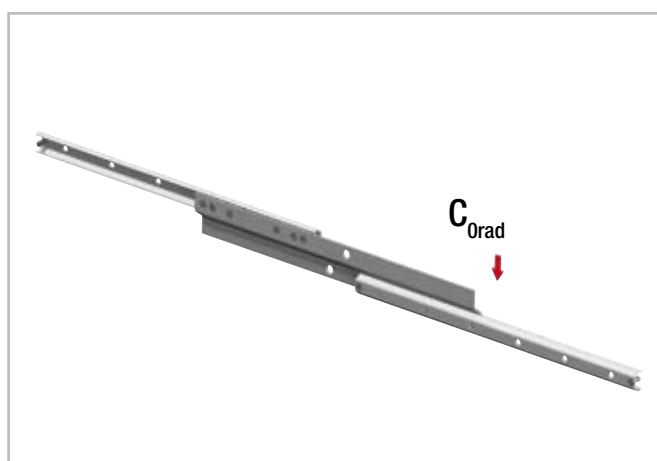

Fig. 10

Type	Length L [mm]	Stroke H [mm]	C_{Orad} [N]
DRX30	400	480	150
	480	560	200
	560	640	240
	640	720	280
DRS30	720	800	320
	800	880	360
	880	960	350
	960	1040	310
	1040	1120	250

The load capacity C_{Orad} refers to a single telescopic rail

Tab. 3

Product dimensions

Fixed bearings

Rail (TEX = stainless steel / TES = zinc-plated steel)

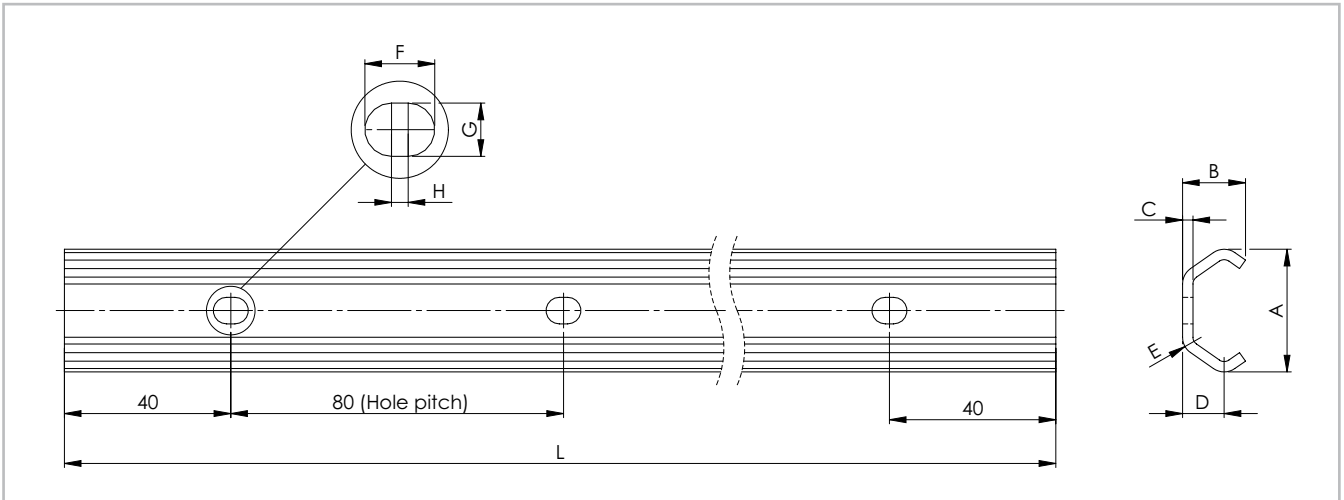

Fig. 11

Rail type	Size	A [mm]	B [mm]	C [mm]	D [mm]	E [mm]	F [mm]	G [mm]	H [mm]	Screw Thread Type	Weight [kg/m]
TEX	20	19.2	10	2	7	3	7	5	2	M4	0.47
	30	29.5	15	2.5	10	4.5	8.4	6.4	2	M5	0.90
TES	45	46.4	24	4	15.5	6.5	11	9	2	M8	2.29

Tab. 4

Rail type	Standard length L [mm]
TEX	160 - 240 - 320 - 400 - 480 - 560 - 640 - 720 - 800 - 880 - 960 - 1040 - 1120 - 1200 - 1280 - 1360 - 1440 - 1520 - 1600 - 1680
TES	- 1760 - 1840 - 1920 - 2000 - 2080 - 2160 - 2240 - 2320 - 2400 - 2480 - 2560 - 2640 - 2720 - 2800 - 2880 - 2960 - 3040 - 3120

Tab. 5

Please specify hole pattern separately
 Special lengths or pitches available upon request, please contact the sales department
 The highlighted rail lengths are available from stock

Slider (CEX = stainless steel / CES = zinc-plated steel)

Version 1 (with compact body)

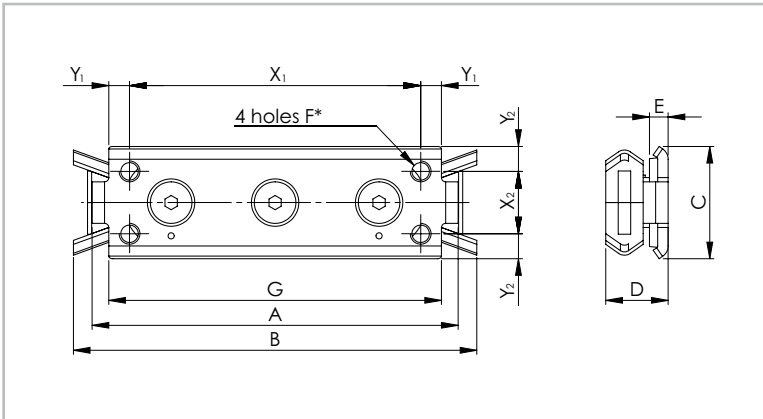

* For size 20: 2 M5 holes on the centreline with distance X₁

Fig. 12

Slider type	Size	A [mm]	B [mm]	C [mm]	D [mm]	E [mm]	F	G [mm]	X ₁ [mm]	Y ₁ [mm]	X ₂ [mm]	Y ₂ [mm]	Weight [kg]
CEX20-80 CES20-80	20	80	90	18	11.5	5.5	M5	71	60	5,5	-	9	0.05
CEX30-88 CES30-88	30	88	97	27	15	4.5	M5	80	70	5	15	6	0.11
CEX45-150 CES45-150	45	150	160	40	22	4	M6	135	120	7.5	23	8.5	0.40

Tab. 6

Version 2 (with solid body)

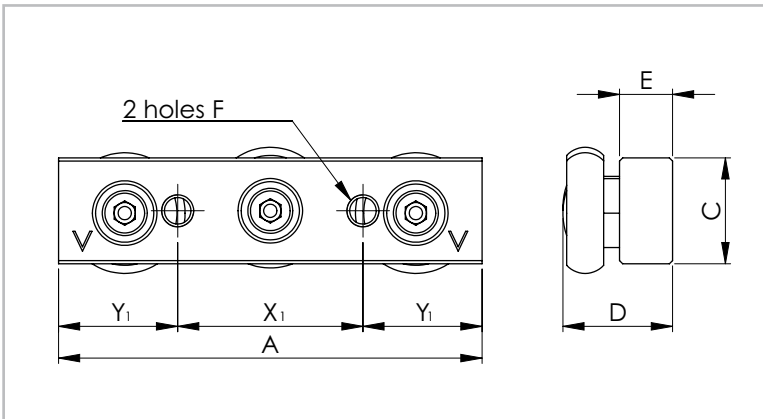

Slider version with wipers on request

Fig. 13

Slider type	Size	A [mm]	C [mm]	D [mm]	E [mm]	F	X ₁ [mm]	Y ₁ [mm]	Weight [kg]
CEX20-60 CES20-60	20	60	10	13	6	M5	20	20	0.04
CEX30-80 CES30-80	30	80	20	20.7	10	M6	35	22.5	0.17
CEX45-120 CES45-120	45	120	25	28.9	12	M8	55	32.5	0.47

Tab. 7

Compensating bearings

Rail (UEX = stainless steel / UES = zinc-plated steel)

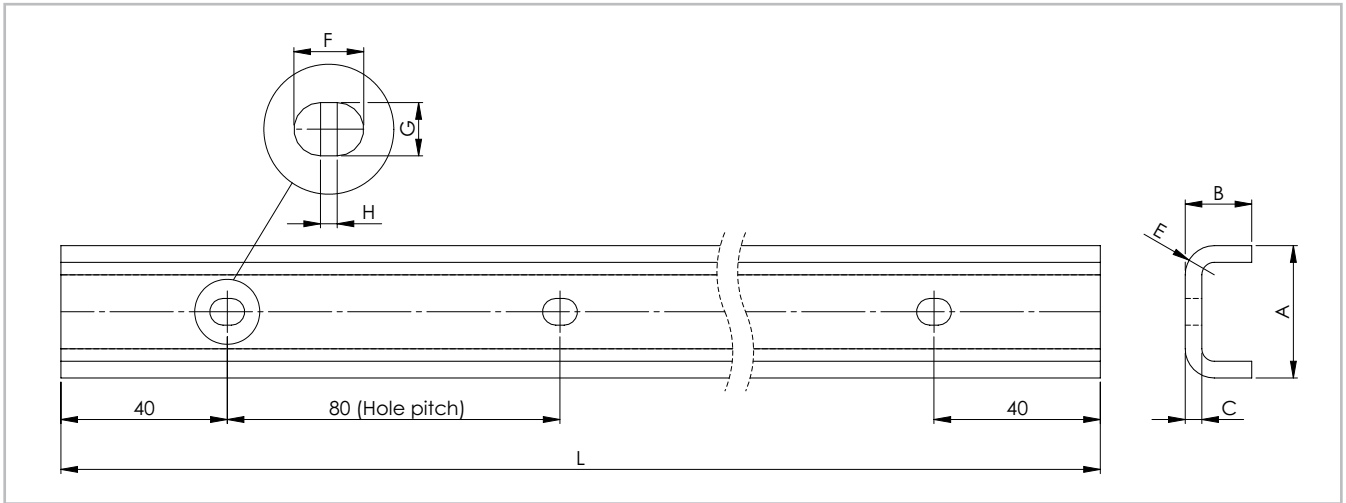

Fig. 14

Rail type	Size	A [mm]	B [mm]	C [mm]	E [mm]	F [mm]	G [mm]	H [mm]	Screw thread type	Weight [kg/m]
UEX	20	20.5	11	3	5.5	7	5	2	M4	0.77
	30	31.8	16	4	7	8.4	6.4	2	M5	1.39
UES	45	44.8	24.5	4.5	9.5	11	9	2	M8	2.79

Tab. 8

Rail type	Standard length L [mm]
UEX	160 - 240 - 320 - 400 - 480 - 560 - 640 - 720 - 800 - 880 - 960 - 1040 - 1120 - 1200 - 1280 - 1360 - 1440 - 1520 - 1600 - 1680
UES	- 1760 - 1840 - 1920 - 2000 - 2080 - 2160 - 2240 - 2320 - 2400 - 2480 - 2560 - 2640 - 2720 - 2800 - 2880 - 2960 - 3040 - 3120

Tab. 9

Please specify hole pattern separately
 Special lengths or pitches available upon request, please contact the sales department
 The highlighted rail lengths are available from stock

Slider (CEXU = stainless steel / CESU = zinc-plated steel)

Version 3 (with solid body)

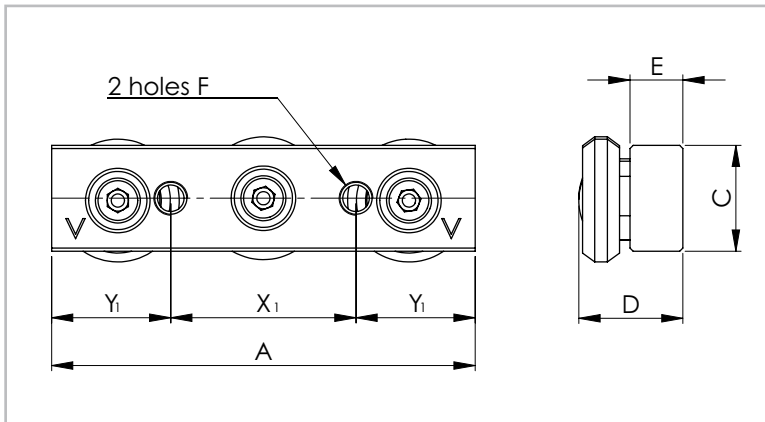

Slider version with wipers on request

Fig. 15

Slider type	Size	A [mm]	C [mm]	D [mm]	E [mm]	F [mm]	X_1 [mm]	Y_1 [mm]	Weight [kg]
CEXU20-60 CESU20-60	20	60	10	11.55	6	M5	20	20	0.04
CEXU30-80 CESU30-80	30	80	20	19.2	10	M6	35	22.5	0.16
CEXU45-120 CESU45-120	45	120	25	25.5	12	M8	55	32.5	0.45

Tab. 10

Mounted sliders and rails

Fixed bearings

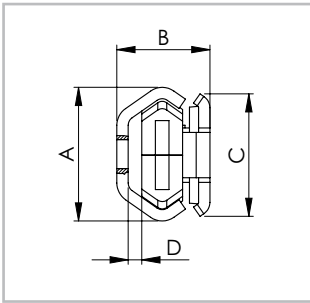

Fig. 16

Version 1
(Slider with compact body)

Configuration	A [mm]	B [mm]	C [mm]	D [mm]
TEX-20 – CEX20-80 TES-20 – CES20-80	19.2	16	18	2.5
TEX-30 – CEX30-88 TES-30 – CES30-88	29.5	20.5	27	3.5
TEX-45 – CEX45-150 TES-45 – CES45-150	46.4	31	40	5

Tab. 11

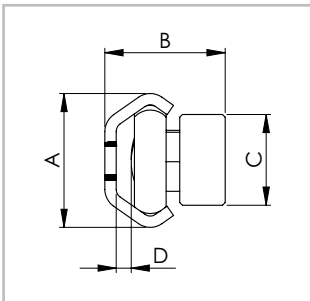

Fig. 17

Version 2
(Slider with solid body)

Configuration	A [mm]	B [mm]	C [mm]	D [mm]
TEX-20 – CEX20-60 TES-20 – CES20-60	19.2	17.8	10	2.6
TEX-30 – CEX30-80 TES-30 – CES30-80	29.5	26.5	20	3.3
TEX-45 – CEX45-120 TES-45 – CES45-120	46.4	38	25	5.1

Tab. 12

Compensating bearings

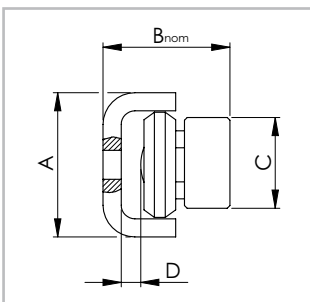

Fig. 18

Version 3
(Slider with solid body)

Configuration	A [mm]	B _{nom} [mm]	C [mm]	D [mm]
UEX-20 – CEXU20-60 UES-20 – CESU20-60	20.5	18.25 ± 0.6	10	2.5
UEX-30 – CEXU30-80 UES-30 – CESU30-80	31.8	27.95 ± 1.0	20	3.5
UEX-45 – CEXU45-120 UES-45 – CESU45-120	44.8	37.25 ± 1.75	25	5

Tab. 13

Telescopic drawer slide

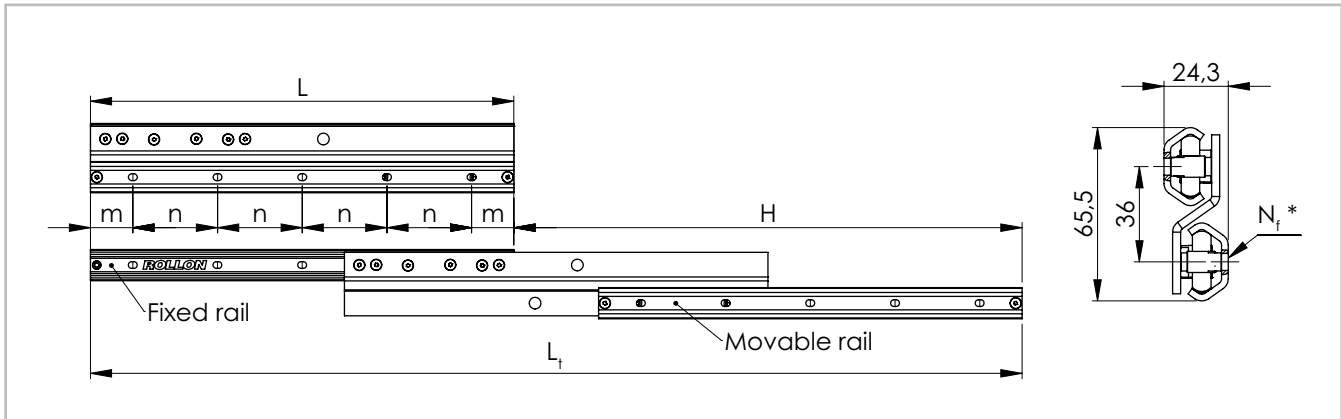

* Number of mounting holes

Fig. 19

Type	Size	Length L [mm]	Stroke H [mm]	Total length L ₁ [mm]	Fixed and movable rail				
					m [mm]	n [mm]	N ₁ [2 rails]	Screw Thread Type	Weight [kg/m]
DRX DRS	30	400	480	880	40	80	10	M5	3.40
		480	560	1040			12		
		560	640	1200			14		
		640	720	1360			16		
		720	800	1520			18		
		800	880	1680			20		
		880	960	1840			22		
		960	1040	2000			24		
		1040	1120	2160			26		

Tab. 14

Accessories

Roller Pins

Version 1

(Slider with compact body)

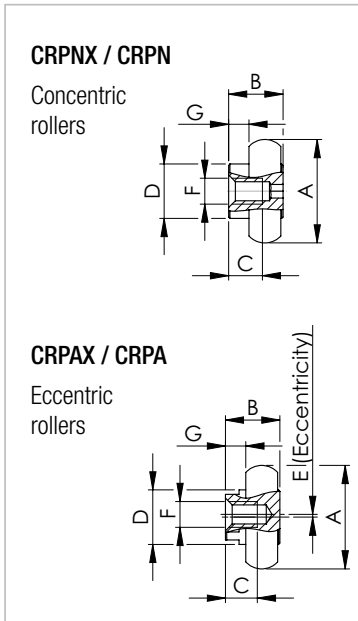

Fig. 20

Roller type	for slider	A [mm]	B [mm]	C [mm]	D [mm]	E [mm]	F	G [mm]	Weight [kg]
CRPNX20-2RS	CEX20-80	14	8.5	6	8	-	M4	4.0	0.006
CRPN20-2Z	CES20-80								
CRPAX20-2RS	CEX20-80					0.5			
CRPA20-2Z	CES20-80								
CRPNX30-2RS	CEX30-88	22.8	12	7	12	-	M5	4.5	0.02
CRPN30-2Z	CES30-88								
CRPAX30-2RS	CEX30-88					0.6			
CRPA30-2Z	CES30-88								
CRPNX45-2RS	CEX45-150	35.6	18	12	16	-	M6	6.0	0.068
CRPN45-2Z	CES45-150								
CRPAX45-2RS	CEX45-150					0.8			
CRPA45-2Z	CES45-150								

Load rate per roller: radial 50 %, axial 33 % of the given slider load rate
2RS (splashproof seal for CEX slider), 2Z (dust cover seal for CES slider)

Tab. 15

Version 2

(Slider with solid body)

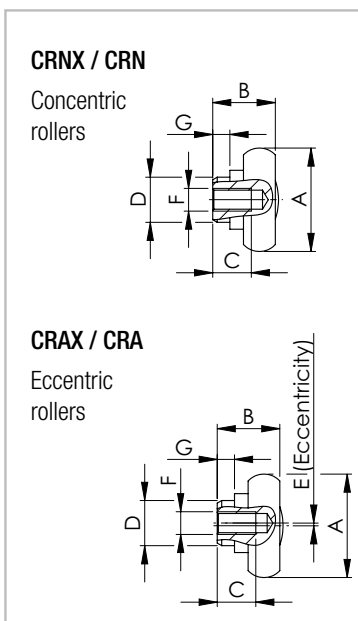

Fig. 21

Roller type	for slider	A [mm]	B [mm]	C [mm]	D [mm]	E [mm]	F	G [mm]	Weight [kg]
CRNX20-2RS	CEX20-60	14	8.7	6	6	-	M4	1.8	0.006
CRN20-2Z	CES20-60								
CRAX20-2RS	CEX20-60					0.5			
CRA20-2Z	CES20-60								
CRNX30-2RS	CEX30-80	22.8	14	9	10	-	M5	3.8	0.022
CRN30-2Z	CES30-80								
CRAX30-2RS	CEX30-80					0.6			
CRA30-2Z	CES30-80								
CRNX45-2RS	CEX45-120	35.6	20.5	14.5	12	-	M6	4.5	0.07
CRN45-2Z	CES45-120								
CRAX45-2RS	CEX45-120					0.8			
CRA45-2Z	CES45-120								

Load rate per roller: radial 50 %, axial 33 % of the given slider load rate
2RS (splashproof seal for CEX slider), 2Z (dust cover seal for CES slider)

Tab. 16

Version 3

(Slider with solid body)

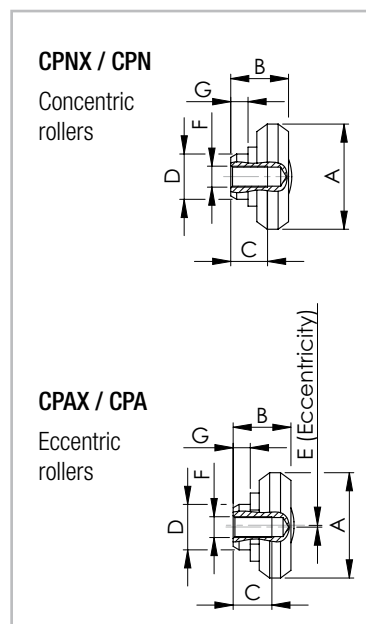

Fig. 22

Roller type	for slider	A [mm]	B [mm]	C [mm]	D [mm]	E [mm]	F	G [mm]	Weight [kg]
CPNX20-2RS	CEXU20-60	14	7.35	5.5	6	-	M4	1.8	0.004
CPN20-2Z	CESU20-60								
CPAX20-2RS	CEXU20-60					0.4			
CPA20-2Z	CESU20-60								
CPNX30-2RS	CEXU30-80	23.2	13	7	10	-	M5	3.8	0.018
CPN30-2Z	CESU30-80								
CPAX30-2RS	CEXU30-80					0.6			
CPA30-2Z	CESU30-80								
CPNX45-2RS	CEXU45-120	35	18	12	12	-	M6	4.5	0.06
CPN45-2Z	CESU45-120								
CPAX45-2RS	CEXU45-120					0.8			
CPA45-2Z	CESU45-120								

Load rate per roller: radial 50 % of given slider load rate
 2RS (splashproof seal for CEX slider), 2Z (dust cover seal for CES slider)

Tab. 17

Fixing screws

We recommend fixing screws according to ISO 7380 with low head height or TORX® screws (see fig.23) on request.

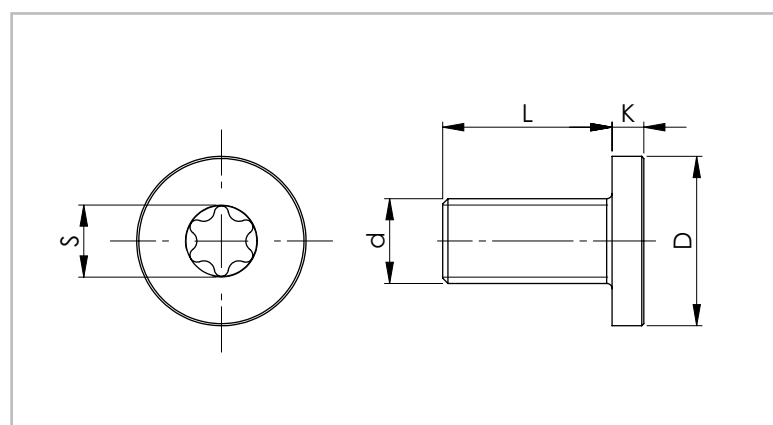

Fig. 23

Rail size	Screw type	d	D [mm]	L [mm]	K [mm]	S	Tightening torque [Nm]
20	M4 x 8	M4 x 0.7	8	8	2	T20	3
30	M5 x 10	M5 x 0.8	10	10	2	T25	9
45	M8 x 16	M8 x 1.25	16	16	3	T40	22

Tab. 18

Technical instructions

Lubrication

All rollers of the X-Rail family are lubricated for life, although a thin film between the rolls and the raceways is recommended.

T+U-System

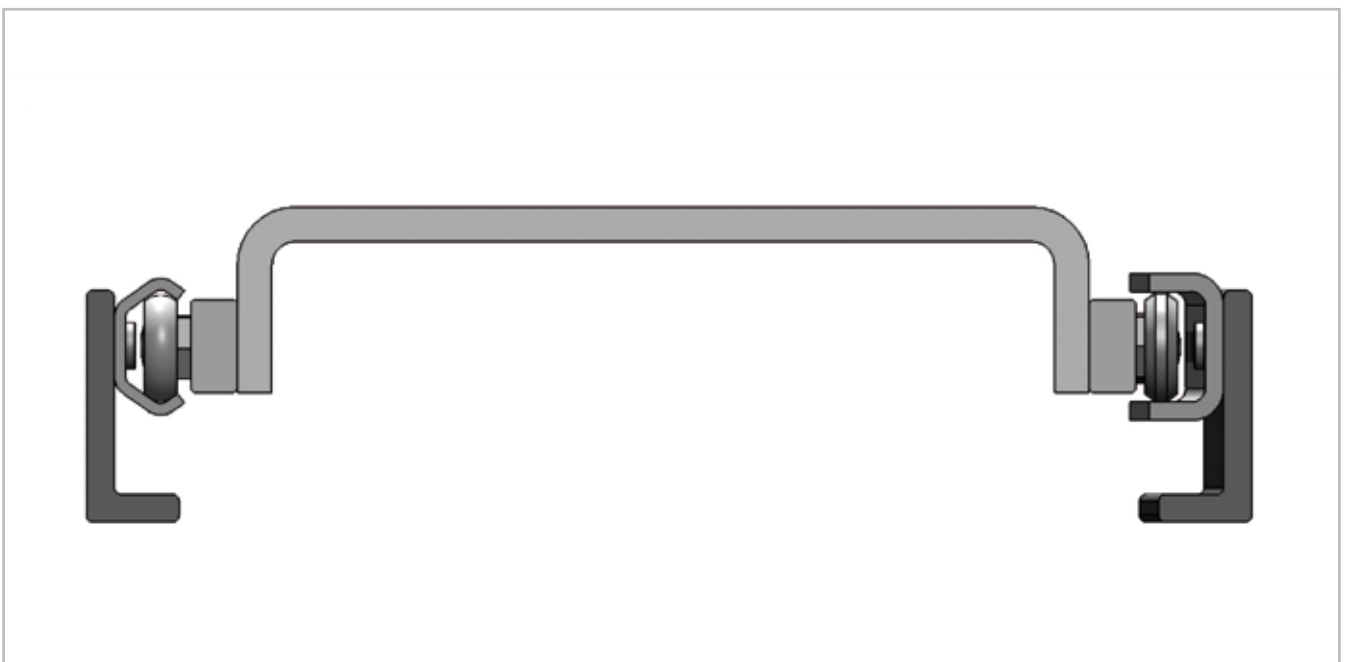

Fig. 24

Solves axial deviations in parallelism

With the fixed/compensating bearing system made of T and U rails, Rollon offers a unique solution to the age-old problem of the parallel mounting of two linear bearings to surfaces that are misaligned and not parallel. This patented solution of a T and U rail allows the sliders to counteract the extreme loads caused by stresses occurring due to insufficient precision in the axial parallelism of the mounting surfaces. This misalignment compensation can drastically increase the service life in an application.

In a T+U-System, the slider in the T rail carries axial and radial loads and guides the movement of the U, which has lateral freedom.

U rails have flat parallel raceways that allow free lateral movement for the sliders. The maximum freedom a slider in the U rail can offer can be calculated using the values S_1 and S_2 (see pg. 17, fig. 25, tab. 19). With nominal value B_{nom} as the starting point, S_1 indicates the maximum allowed movement into the rail, while S_2 represents the maximum offset towards the outside of the rail.

If the length of the guide rail is known, the maximum allowable angle deviation of the mounting surface (see pg. 17, fig. 26). In this case the slide in the U rail has the freedom to travel from the innermost position S_1 to the outermost position S_2 .

Maximum offset

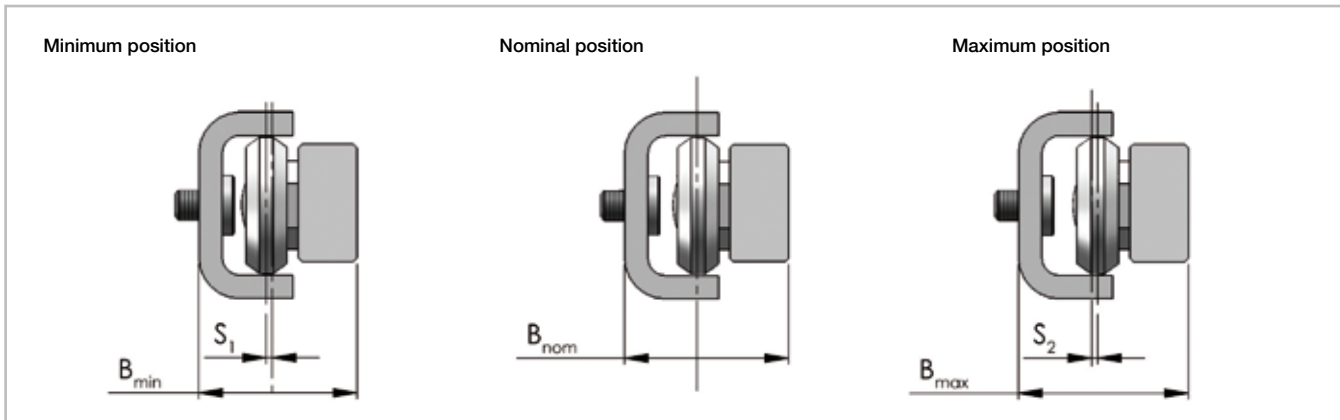

Fig. 25

Slider type (Version 3 with solid body)	S ₁ [mm]	S ₂ [mm]	B _{min} [mm]	B _{nom} [mm]	B _{max} [mm]
CEXU.../CESU20-60	0.6	0.6	17.65	18.25	18.85
CEXU.../CESU30-80	1	1	26.95	27.95	28.95
CEXU.../CESU45-120	1.75	1.75	35.50	37.25	39

Tab. 19

Guideline for the maximum angle deviation α, achievable with the longest guide rail

$$\alpha = \arctan \frac{S^*}{L}$$

S* = sum of S₁ and S₂
L = length of the rail

Fig. 26

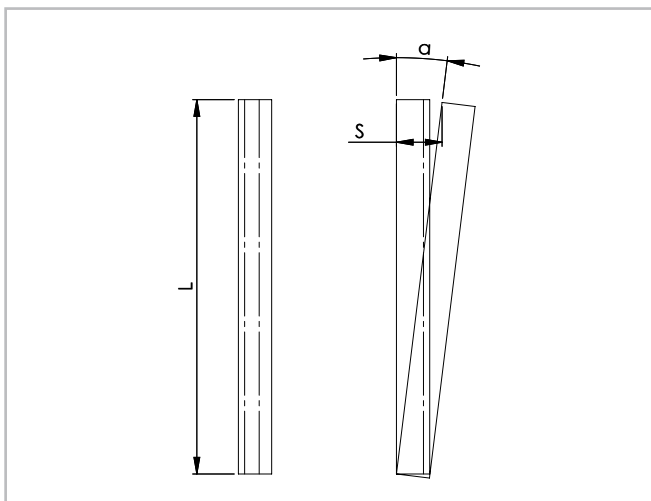

Fig. 27

Size	Rail length [mm]	Offset S* [mm]	Angle α [°]
20	3120	1.2	0.022
30	3120	2	0.037
45	3120	3.5	0.064

Tab. 20

Setting preload

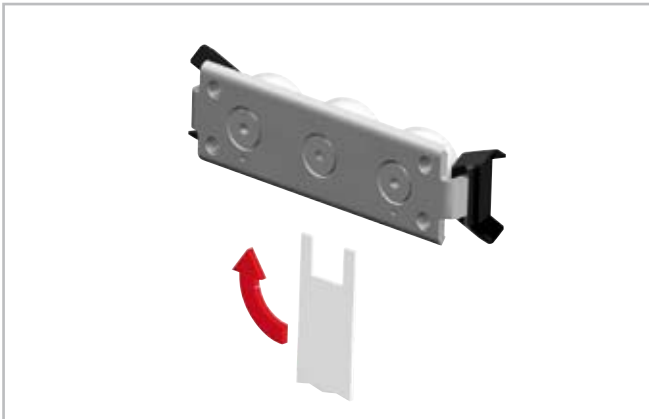

Fig. 28

If the product is delivered with the sliders in the rails, the sliders are already preloaded. If delivered separately, or if the sliders need to be installed in another rail, the sliders must be readjusted. In this case, follow the instructions below:

- Wipe the raceways of any eventual dirt and debris.
- If necessary, remove existing wipers and insert the sliders into the rails. Slightly loosen the fixing screw of the center roller pin.
- Position the slider(s) at the ends of the rail.
- For the U rails there must be a thin support (e.g. set key) under the ends of the slider body to ensure the horizontal alignment of the slider in the flat raceways.
- The included special flat key is inserted from the side between the rail and the slider and plugged onto the hexagonal or square shaft of the eccentric pin to be adjusted (see fig. 28).
- By turning the flat key clockwise, the eccentric roller is pressed against the upper raceway, thereby removing clearance and setting a correct preload. During this process, absence of play is desired; avoid a setting a preload that is so high that it generates higher friction and reduces service life.
- Hold the roller pin with the adjustment key in the desired position and carefully tighten the fixing screw. The exact tightening torque will be checked later.
- Move the slider in the rail and check the preload over the entire length of the rail. It should move easily and the slider should not have play at any location of the rail.
- Tighten the fixing screw with the specified tightening torque (see tab. 21), while holding the flat key and maintaining the angle position of the pin so as to not change the preload with the screw tightening.
- Now re-attach the existing wipers if desired.

Size	Tightening torque [Nm]
20	3
30	7
45	12

Tab. 21

Telescopic drawer slide mounting

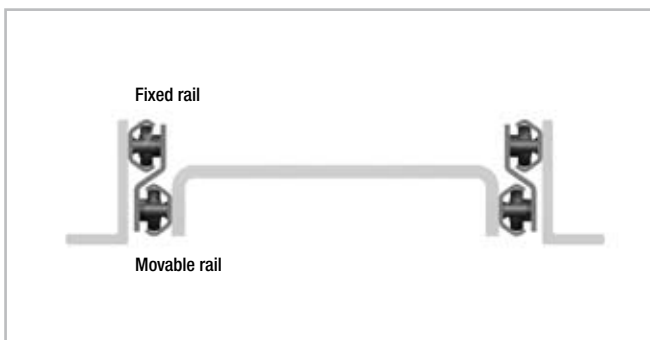

Fig. 29

- The external loads should act on the radial centre, i.e. in the vertical cross-sectional axis on the movable rails (see pg. 7, fig.10).
- During installation care must be taken that the movable elements are assembled as in the figure; i.e. as the lower rail. The opposite upside-down assembly negatively affects the function.
- The mounting structures must be rigid. All standard, available mounting holes must be used.
- When mounted as pairs, the mounting parallelism is very important and will effect slide quality.
- The telescopic drawer slide DRX / DRS must only be mounted horizontally. If the application requires vertical movement, please contact our technical customer service.

 Notes

Ordering key

Rail / slider system

TEX-	960	/1/	CEX20-60	-2RS
			Roller seal	<i>see pg. 6 Performance characteristics</i>
			Slider type	<i>see pg. 9, tab. 6 and 7/ pg. 11, tab. 10</i>
			Number of sliders in one rail	
	Rail length in mm		<i>see pg. 8, tab. 5 / pg.10, tab. 9</i>	
Rail type	<i>see pg. 8, tab. 4 / pg. 10, tab. 8</i>			

Ordering example: TEX-00960/1/CEX20-060-2RS

Hole pitch: 40-11 x 80-40

Notes on ordering: The rail length codes are always 5 digits, the slider length codes are always 3 digits; use zeroes as a prefix when lengths are shorter

Rail

TEX-	30-	960
		Rail length in mm <i>see pg. 8, tab. 5 / pg.10, tab. 9</i>
	Size	<i>see pg. 8, tab. 4 / pg. 10, tab. 8</i>
Rail type	<i>see pg. 8, tab. 4 / pg.10, tab. 8</i>	

Ordering example: TEX-30-00960

Hole pattern: 40-11 x 80-40

Notes on ordering: The rail length codes are always 5 digits; use zeroes as a prefix when lengths are shorter

Slider

CES30-80	-2Z
	Roller seal <i>see pg. 6 Performance characteristics</i>
Slider type	<i>see pg. 9, tab. 6 and 7/ pg. 11, tab. 10</i>

Ordering example: CES30-080-2Z

Notes on ordering: The slider length codes are always 3 digits; use zeroes as a prefix when lengths are shorter

Telescopic

DRX	30-	400
		Rail lengths L <i>s. pg. 13, tab. 14</i>
	Size	
Type	<i>see pg. 13, tab. 14</i>	

Ordering example: DRX30-0400

Notes on ordering: The Telescopic Rail length codes are always 4 digits; use zeroes as a prefix when lengths are shorter

Accessories

Roller pins

CRPAX	45	-2RS	
		Roller seal	<i>see pg. 6 Performance characteristics</i>
	Size	<i>see pg. 14ff, tab. 15-17</i>	
Roller type	<i>see pg. 14ff, tab. 15-17</i>		

Ordering example: CRPAX45-2RS

Fixing screws

Rail type	Size	Ordering description
TEX / UEX	20	TORX®-screw TC 18 M4x8 NIC
	30	TORX®-screw TC 28 M5x10 NIC
	45	TORX®-screw TC 43 M8x16 NIC
TES / UES	20	TORX®-screw TC 18 M4x8
	30	TORX®-screw TC 28 M5x10
	45	TORX®-screw TC 43 M8x16
DRX	30	TORX®-screw TC 28 M5x10 NIC
DRS	30	TORX®-screw TC 28 M5x10

see pg. 17, fig. 23, tab. 18

Portfolio



COMPACT RAIL

Rugged roller sliders with innovative self adjustment



MONO RAIL

Profile guideways for highest degrees of precision



CURVILINE

Curvilinear rails for constant and variable radii



MINIATURE MONO RAIL

Miniature format profile guideways with unique ball design

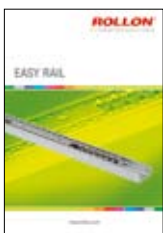

EASY RAIL

Compact, versatile linear bearings



TELESCOPIC RAIL

Smooth-running telescopic linear bearing drawer slides with low deflection under heavy loads



UNILINE

Steel-reinforced, belt-driven linear actuators with hardened steel linear bearings and precision radial ball bearing rollers

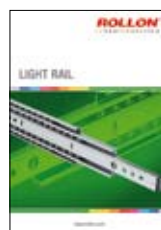

LIGHT RAIL

Full and partial extension, lightweight drawer slides

Fold out ordering key

To make this product catalog as simple as possible for you to use, we have included the following easy-to-read chart.

Your advantages:

- Description and ordering designations easy to read at one glance
- Simplified selection of the correct product
- Links to detailed descriptions in the catalog



Italy

ROLLON S.r.l.

Via Trieste 26
I-20871 Vimercate (MB)
Tel.: (+39) 039 62 59 1
Fax: (+39) 039 62 59 205
E-Mail: infocom@rollon.it
www.rollon.it

Germany

ROLLON GmbH

Voisweg 5c
D-40878 Ratingen
Tel.: (+49) 21 02 87 45 0
Fax: (+49) 21 02 87 45 10
E-Mail: info@rollon.de
www.rollon.de

France

ROLLON S.A.R.L.

Les Jardins d'Eole, 2 allée des Séquoias
F-69760 Limonest
Tel.: (+33) (0)4 74 71 93 30
Fax: (+33) (0)4 74 71 95 31
E-Mail: infocom@rollon.fr
www.rollon.fr

Netherlands

ROLLON B.V.

P.O. Box 1916900 AD Zevenaar
Tel.: (+31) 316 581 999
Fax: (+31) 316 341 236
E-Mail: info@rollon.nl
www.rollon.nl

USA

ROLLON Corporation

101 Bilby Road. Suite B
Hackettstown, NJ 07840
Tel.: (+1) 973 300 5492
Fax: (+1) 908 852 2714
E-Mail: info@rolloncorp.com
www.rolloncorp.com

All addresses of our global sales partners can also
be found in the internet at www.rollon.com